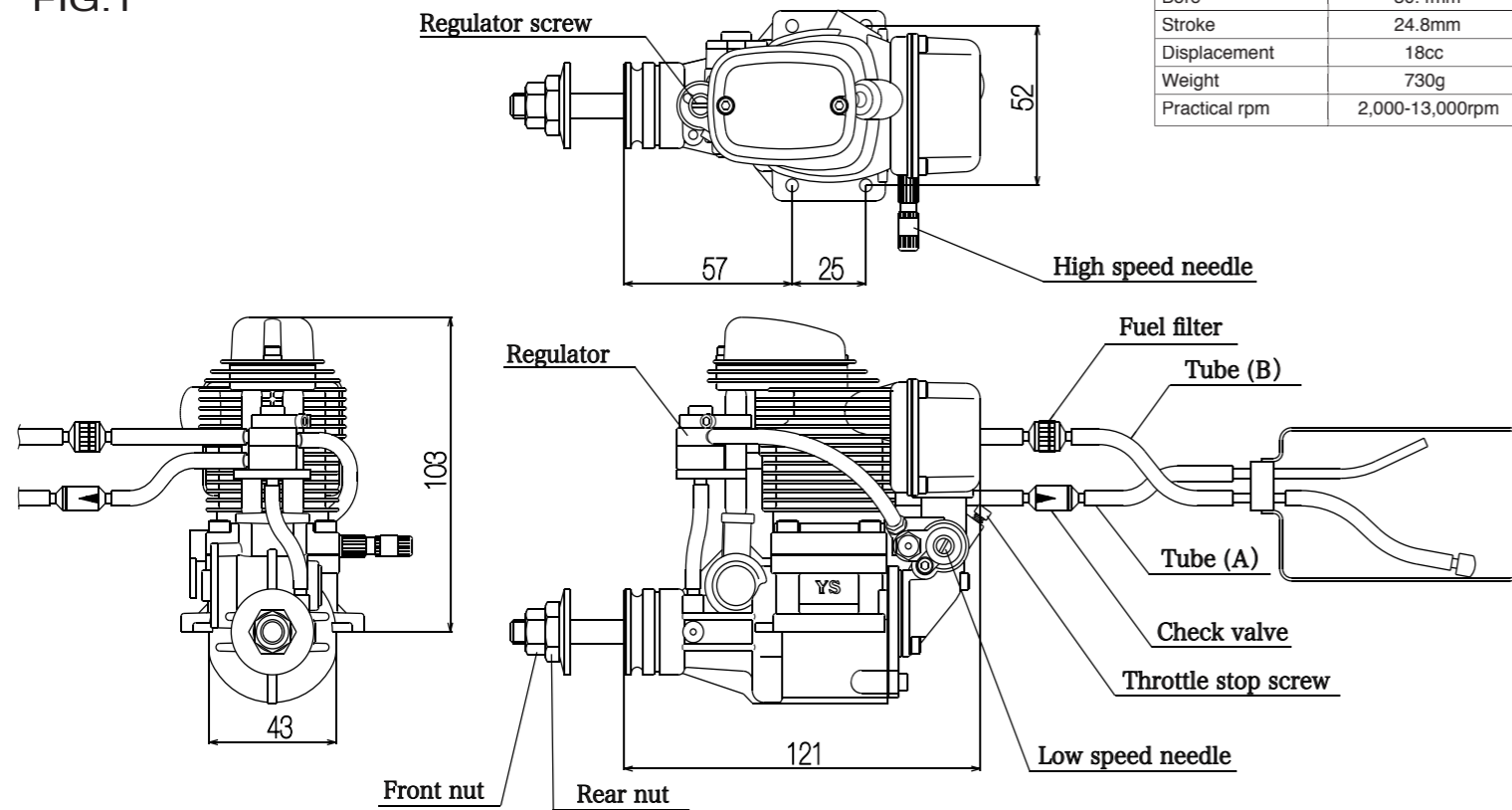

FIG.1



### SPECIFICATIONS

Bore	30.4mm
Stroke	24.8mm
Displacement	18cc
Weight	730g
Practical rpm	2,000-13,000rpm

### FEATURES

The FZ110S is the most powerful 110 four cycle engine available. This engine offers many exclusive features that have been proven on other YS engines.

Supercharged system with simplified structure to keep weight to a minimum while still retaining maximum efficiency.

Air chamber that uses crankcase pressure coupled with a double throttle valve system which allows a bigger charge of fuel and air mixture to enter the intake valve for more power.

Fuel injection system for superior throttle response. This system is unaffected by tank position or by the attitude of the model.

### GIOW PLUG

Select the most appropriate glow plug from those designed specifically for 4 cycle engines. Glow plug selection greatly affects the maximum engine output and low idle. If RPM's decrease or stop when the booster cord is removed, replace the plug.

We recommend YS #4 (P0040) or OS Type F.

### INSTALLATION

1. Connect the engine to the tank as shown in FIG.1. Since high pressure is applied to the tank, tighten all connections carefully. Care must be taken to prevent pressure leakage due to undertightening of the check valve or by kinking the fuel lines.
2. Always uses a fuel filter ( not included ). We recommend the YS filter ( 6720 ).
3. Match the direction of the check valve arrow to FIG.1, with the arrow facing towards the tank.

### PROPELLER INSTALLATION

Due to the high torque of the FZ110S engine, we have equipped it with double locknuts for safety.

1. Mount the propeller and tighten the rear nut. Next, tighten the front nut as shown in FIG.1.
2. Select a good quality propeller that will turn in the 8,000 to 11,000rpm range. We recommend sizes 14x11-12, 15x10-11

### START-UP

1. Remove tube(B) from the filter, remove tube(A) from the check valve, then fill the tank.  
Caution: If tank is filled or under pressure remove tube(A) first; then tube(B). Fuel will eject if tube(B) is removed first while the tank is pressurized.
2. Open the needle valve 1 1/4~1/2 from the fully closed position.
3. Open the throttle fully and slowly turn the propeller ten turns. This primes the system by pressurizing the tank and sending fuel to the carburetor.
4. Pour several drops of fuel into the carburetor.
5. Close the throttle to the idle position and connect the glow plug cord. The engine is now ready for starting.

Do not attempt to start at full throttle, as this is very dangerous.

### BREAK-IN

To maximize engine performance and increase durability, please follow this break-in procedure:

1. Use the same size (or slightly smaller) propeller than you intend to use in flying.
2. Use a good quality fuel which contains 15-30% nitromethane and an oil content of 15-20%. Synthetic or castor oil can be used, or a combination of synthetic and castor. Do not use four cycle fuel due to low oil content.
3. The needle valve should be set so that the engine is running at a rich setting. Run the engine approximately 20 minutes with this setting.
4. Mount the engine to the model and fly ten times with this setting. This concludes the break-in procedure. It is advisable to always use a slightly rich setting to keep the moving parts lubricated, even after the break-in period.

### HIGH SPEED ADJUSTMENT

1. Adjustment of high speed is done by the high speed needle valve. When it is turned clockwise, the mixture is leaner. When it is turned counterclockwise, the mixture is richer. A good starting position for the high speed needle valve is 1 1/4 turns open from fully close position.
2. When the engine is started, open the throttle gradually. Next, find the peak position (highest RPM) by adjusting the needle valve. Then the needle valve should be opened approximately 1/8 of a turn from full RPM to achieve best performance. The engine may stop if the throttle is opened to full immediately after starting. Wait until the engine temperature rises and then open the throttle slowly.

3. For flying, it is advisable to use a slightly richer mixture setting. By using a richer mixture, the engine temperature is maintained and RPM stability improves.

### LOW SPEED ADJUSTMENT

This engine is equipped with a low speed needle valve to adjust the mixture from low to mid throttle. This needle valve is located on the side of the throttle barrel opposite the throttle arm (FIG.1).

1. Open the low speed needle to 3 turns from fully closed position.
2. The low speed needle valve should be set after the high speed needle valve has been adjusted. Close the throttle gradually to a idle (approximately 2300rpm). Let it idle for 20 to 30 seconds and then slowly advance the throttle. The adjustment is satisfactory at low speed if transition is smooth at this time.
3. If the engine is running rough on idle, the low speed mixture is rich. If the engine starts to speed up and dies on idle or starts to detonate, when advancing the throttle, the mixture is lean. Turn the low speed needle valve clockwise to richen and counterclockwise for a leaner mixture (note that the direction of the low speed needle valve is opposite the high speed needle valve). Adjustments to the low speed needle valve should be 1/8 to 1/4 of a turn increment at a time to achieve smooth throttle response.

FIG.2

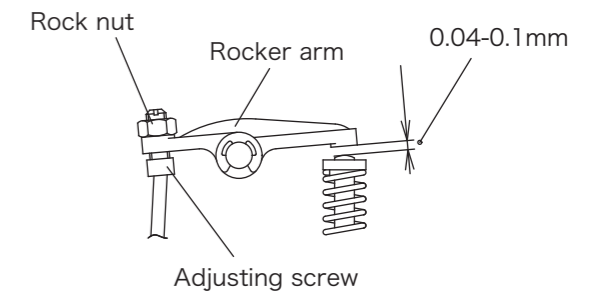

### TAPPET CLEARANCE ADJUSTMENT

1. Tappet clearance is factory preset. No adjustment is necessary unit after 1 hour of operation(including break-in period).
2. Clearance adjustment should be done when the engine is cool. When the engine temperature is high, clearance is higher due to thermal expansion.
3. The proper clearance setting should be at 0.04-0.1mm. The adjustment is achieved by loosening the locknut (FIG.2) and turning the adjusting screw. Tighten the locknut after the adjustment is achieved. After the initial 1 hour adjustment, this procedure should be performed after every 2 hours of use.

### CAMGEAR TIMING ADJUSTMENT

If for some reason you have to disassemble your engine, please follow these important steps on reassembling the cam gear.

1. Remove the carburetor and backplate assembly. Notice the impression made on the crankshaft counterweight. Position it directly straight down or in line with the case outer seam line.
2. When reinstalling the cam gear, the side with a point mark should be facing the opening of the gear box. Note that it should also be mounted with the point mark located towards the top of the engine just below the cam followers.

**IMPORTANT!** Silicone rubber is used in many parts of the YS engine. Use only glow fuel or methanol for cleaning. Gasoline and other volatile solutions will damage the silicone if used.

### WARRANTY

Strict quality control is implemented by our factory in all phases, from parts manufacturing to final assembly. If performance deteriorates or a part fails due to a manufacturing error, YS will repair or replace the engine at no charge in the period of one year from date of purchase. Warranty does not cover normal maintenance.

Should the engine be modified, incorrectly assembled or abused, there will be a normal charge for parts and labor. The use of four cycle fuel due to the low oil content will also void warranty.

NO.	PART #	DESCRIPTION	QTY
1	F7301	Crankcase	1
	F7302A	Cylinder head assembly	
2	F7302	Cylinder head	1
3	F9103	Intake valve	1
4	F9104	Exhaust valve	1
5	F1209	Valve spring set	2
6	F9106	Spring retainer set	2
7	F9107	Spring retainer clips	4
8	F7308	Cylinder gasket	1
9	F7309	Head screws	4
10	F9112	Valve cover	1
11	F9113	Valve cover gasket	1
12	F9114	Valve cover screws	2
13	F9115	Rear air chamber	1
14	F9116	Air chamber gasket	1
15	F9117	Air chamber screws	4
16	F9118	Air chamber O ring	1
17	F7317	Crankshaft	1
18	F7318	Crankshaft ring	1
19	F7319	Rear bearing	1
20	R6211	Front bearing	1
21	F9122	Front bearing oil seal	1
22	F9323	Drive washer	1
23	F9324	Drive washer retainer	1
24	F1266	Propeller washer	1
25	F1267	Propeller nut set	2
26	F1421	Piston	1
27	F1224	Piston ring	1
28	F1222	Wrist pin	1
29	F1323	Wrist pin retainer	2
30	F9131	Rocker arm set	2
31	F1213	Tappet adjusting screw set	2
32	F1214	Tappet adjusting nut set	2
33	F9134	Rocker arm shaft	1
34	F9135	Rocker arm shaft screw	1
35	F1217	E ring set	2
36	F1235	Cam gear	1
37	F9138	Cam gear cover	1
38	F1233	Cam gear cover O ring	1
39	F9140	Cam gear screws	2
40	F1242	Cam gear bearing set	2
41	F1236	Cam follower set	2
42	F9143	Push rods	2
43	F9144	Push rod covers	2
44	F1239	Push rod cover O rings	4
45	F7345	Con rod	1
	F7346A	Back plate assembly	
46		Back plate	1
47		Disc valve	1
48		Disc valve pin	1
49	F7349	Disc valve set screw	1
50	F9152	Back plate gasket	1
	F7351A	Carburetor assembly	
51	F9354	Carburetor body	1
52	F7352	Throttle valve	1
53	F9156	Low speed needle valve	1
54	F9157	Low speed needle valve O ring	1
55	F9358	Throttle barrel seal	1
56	R6124	Throttle valve retainer	1
57	F1260S	Throttle arm set	1
58	F1258	Throttle stop screw	1
59	F1259	Throttle stop spring	1
	F1545S	Needle valve assembly	
60	F1545	Needle valve	1
61	F1546	Needle valve O ring	1
62	F1555	Needle valve seat	1
63	F1556	Needle valve seat O ring	2
64	F1557	Needle valve detent	1
65	F7365	Nipple	1
66	F9164	Carburetor gasket	1
67	F7367	Carburetor screws	6
	F7368A	Regulator assembly	
68	F3168	Regulator adjusting screw	1
69	F3169	Regulator adjusting screw O ring	1
70	F3170	Plunger spring	1
71	F3171	Plunger	1
72	F3172	Regulator body A	1
73	F3173	Diaphragm	1
74	F7374	Regulator body B	1
75	F7375	Stay lower	1
76	F7376	Stay upper	1
	F9377A	Muffler set	
77	F9377	Muffler assembly	1
78	F9378	Exhaust pipe	1
79	F9379	Rock nuts	2
	F7390	Gasket set	5
	F9391	O ring set	11

